

(No Model.)

7 Sheets—Sheet 1.

T. A. EDISON.
PHONOGRAPH.

No. 499,879.

Patented June 20, 1893.

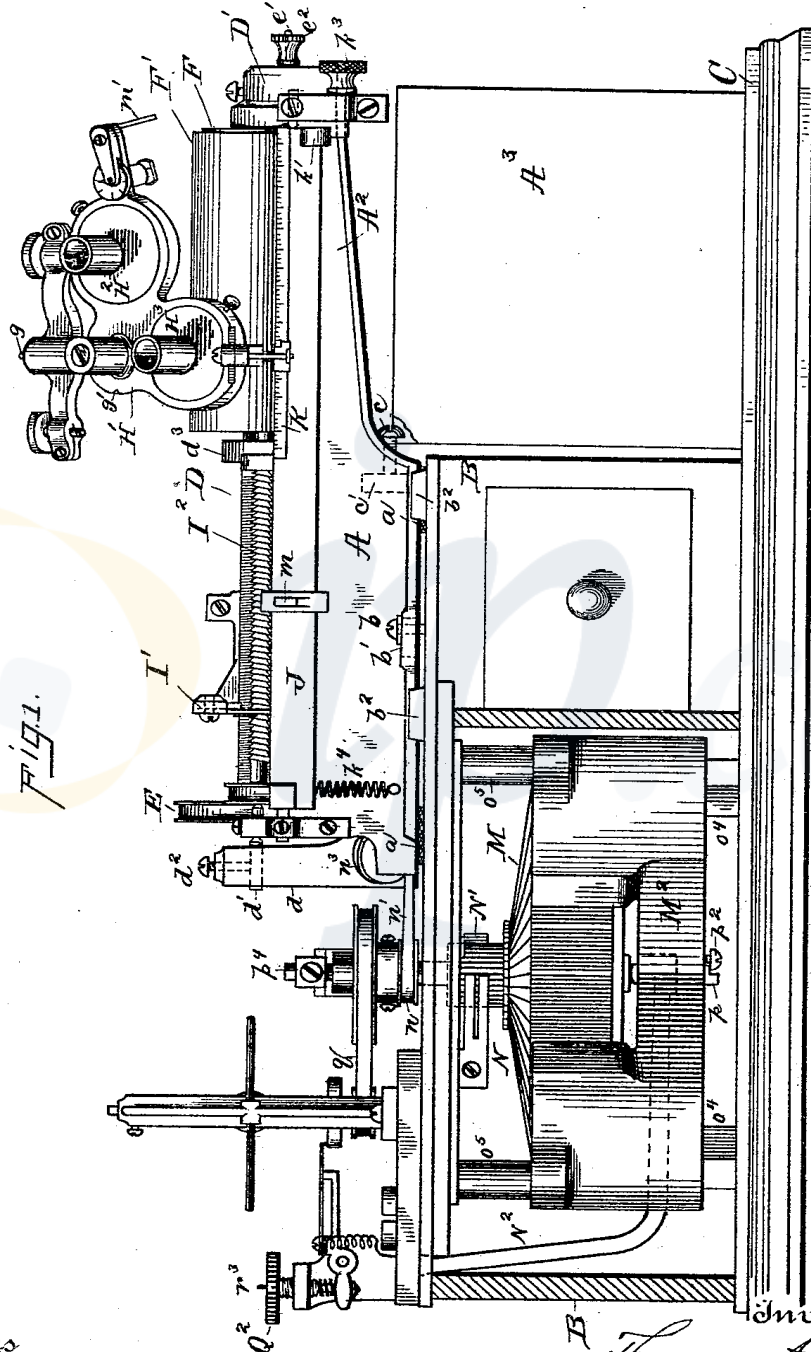

FIG. 1.

Witnesses
E. Howard
William Pizer

Inventor
Thomas A. Edison.

By his Attorneys
Dyer & Seely.

(No Model.)

7 Sheets—Sheet 2.

T. A. EDISON.
PHONOGRAPH.

No. 499,879.

Patented June 20, 1893.

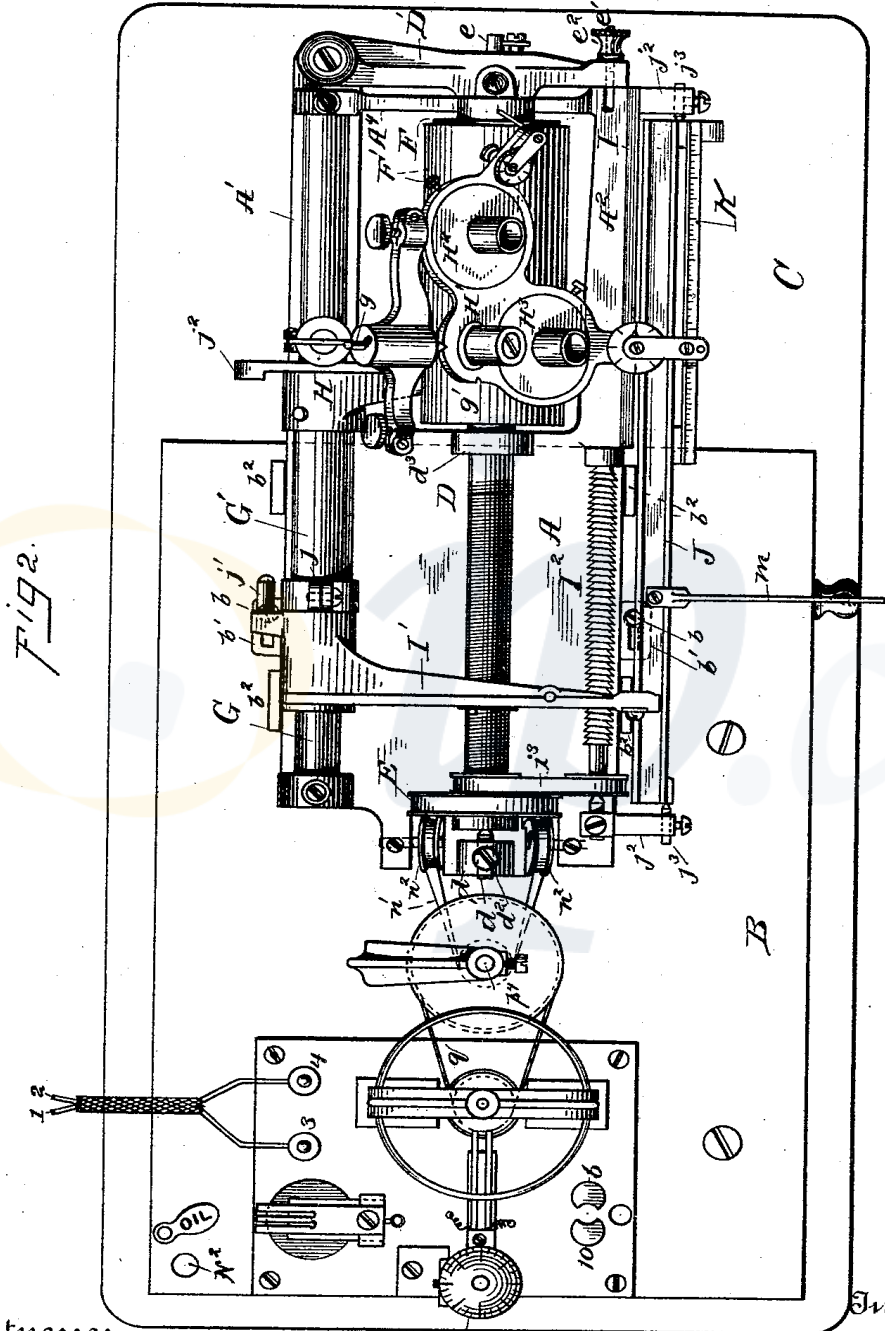

Fig. 2.

Witnesses
Ed. Rowland
William Pizer

Inventor
Thomas A. Edison
By his Attorneys
Dyer & Seely

(No Model.)

7 Sheets—Sheet 3.

T. A. EDISON.
PHONOGRAPH.

No. 499,879.

Patented June 20, 1893.

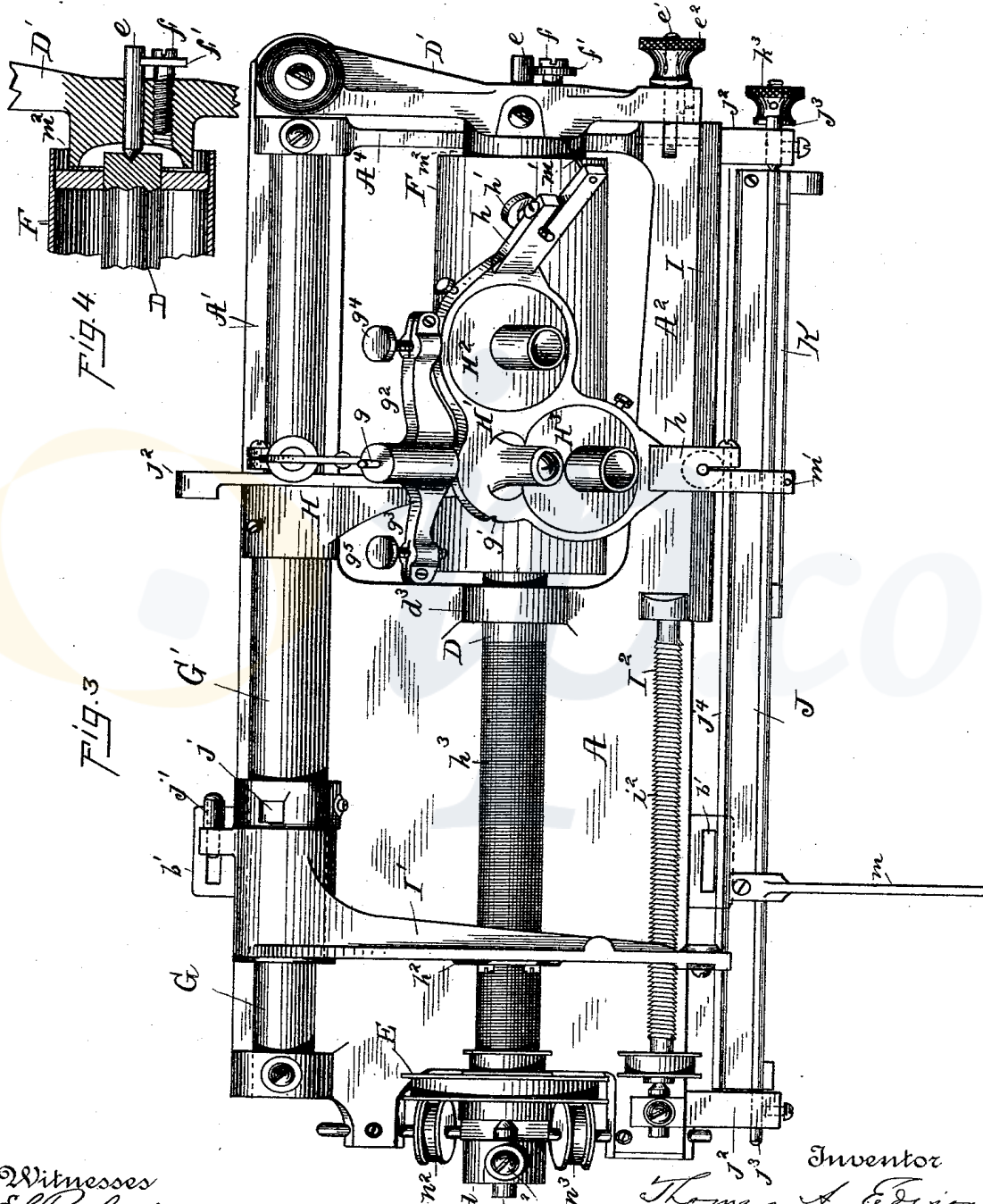

Witnesses
Ed Rowland
William Oger

Inventor
Thomas A. Edison
 By his Attorney
Dyer & Keely.

(No Model.)

7 Sheets—Sheet 4.

T. A. EDISON.
PHONOGRAPH.

No. 499,879.

Patented June 20, 1893.

FIG. 5.

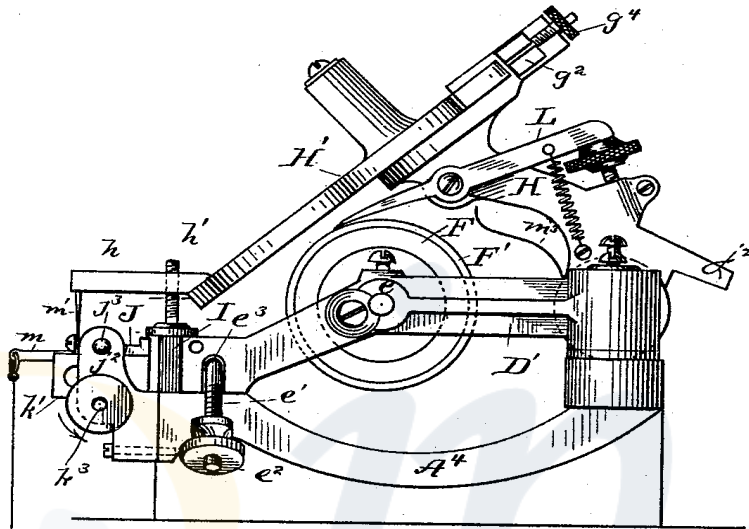
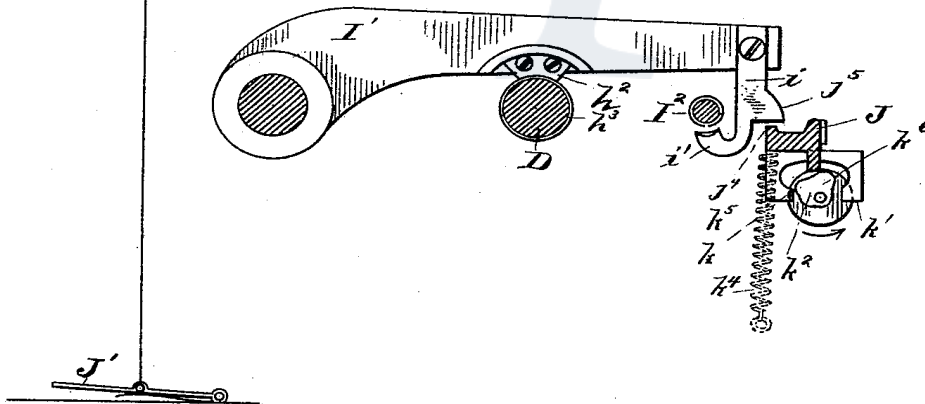

FIG. 6.



Witnesses
E. Rowland.
William P. Boyer

Inventor
Thomas A. Edison.
 By his Attorneys
Dyer & Seely.

(No Model.)

T. A. EDISON.
PHONOGRAPH.

7 Sheets—Sheet 5.

No. 499,879.

Patented June 20, 1893.

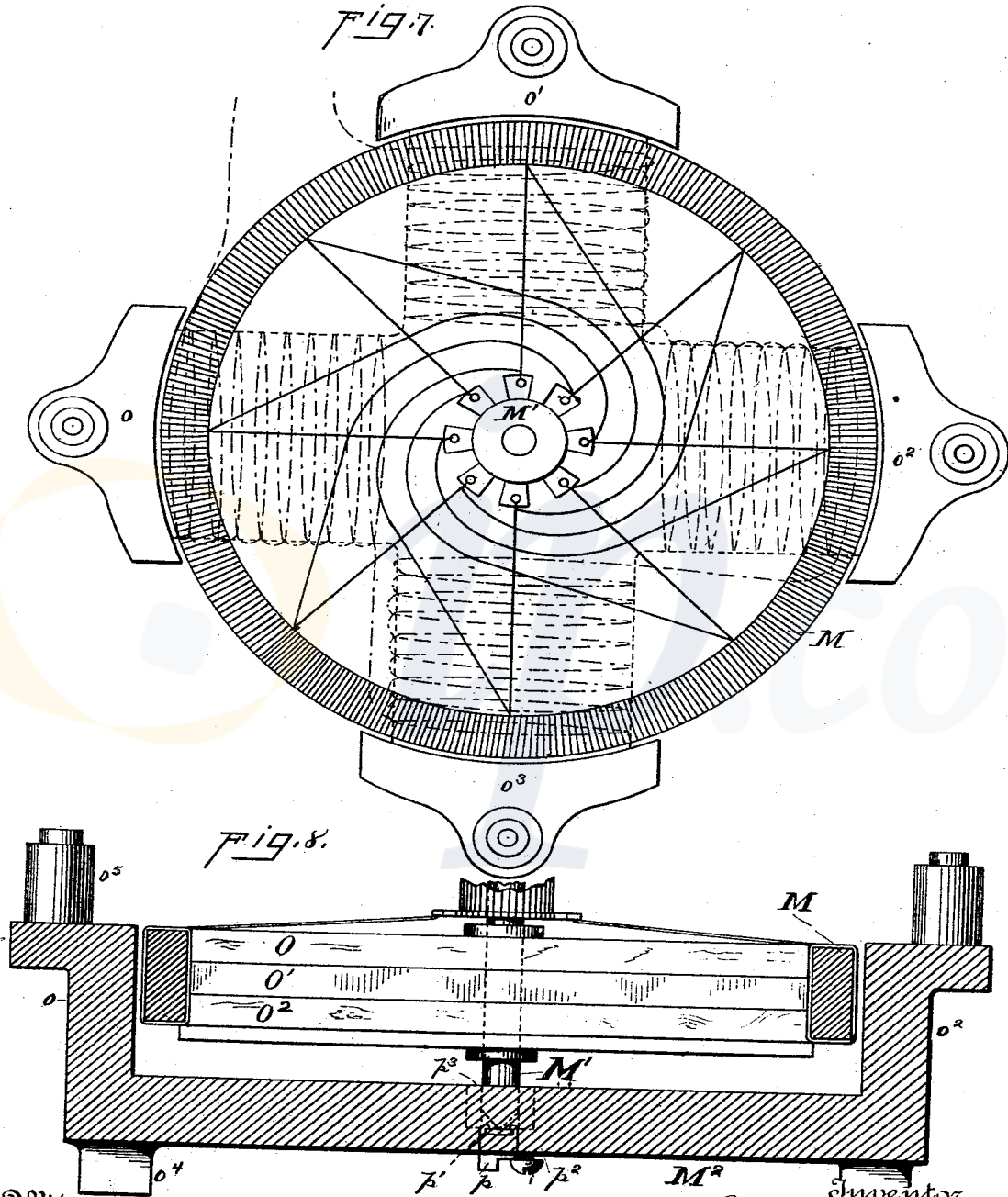

Witnesses
E. S. Rowland.
William Pizer

Inventor
Thomas A. Edison.

By his Attorney
Dyer & Seely

(No Model.)

T. A. EDISON.
PHONOGRAPH.

7 Sheets—Sheet 6.

No. 499,879.

Patented June 20, 1893.

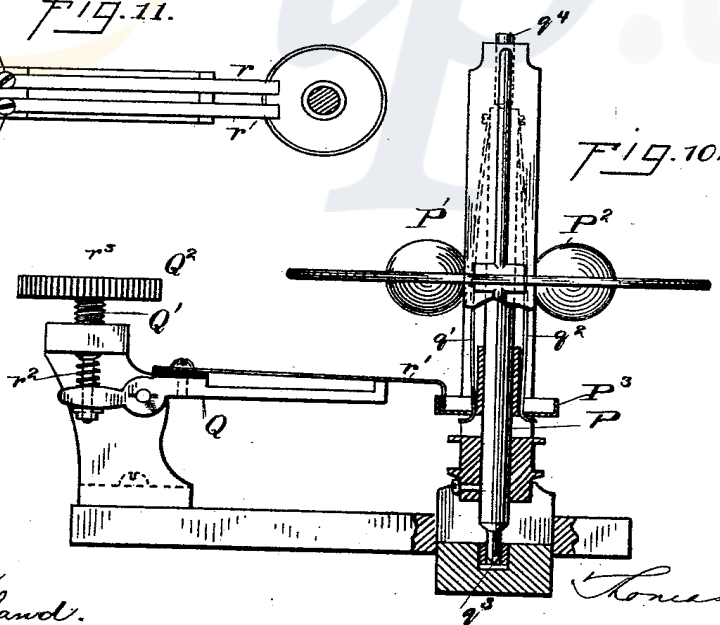
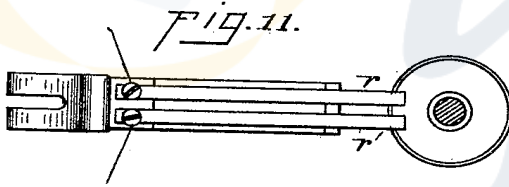
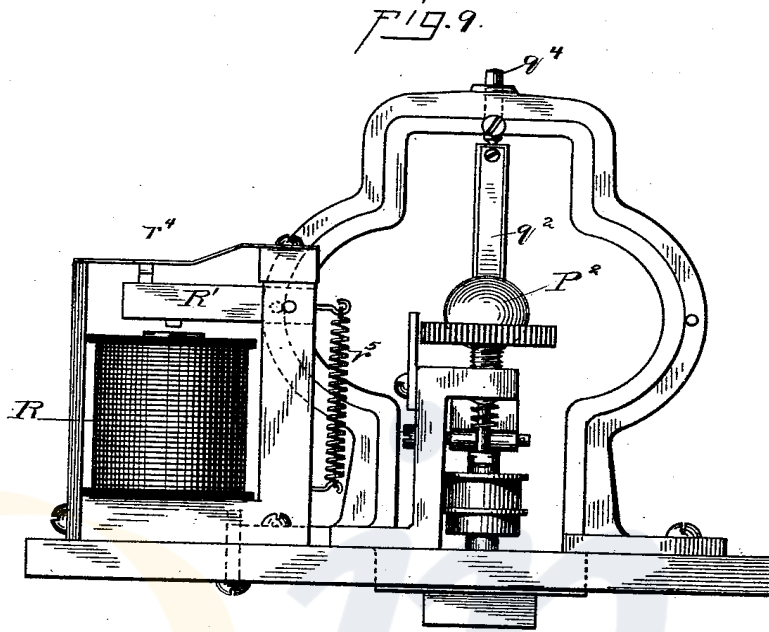

Witnesses
E. Rowland.
William Eyer

Inventor
Thomas A. Edison.
 By his Attorneys
Dyer & Seely.

(No Model.)

T. A. EDISON.
PHONOGRAPH.

7 Sheets—Sheet 7.

No. 499,879.

Patented June 20, 1893.

FIG. 12.

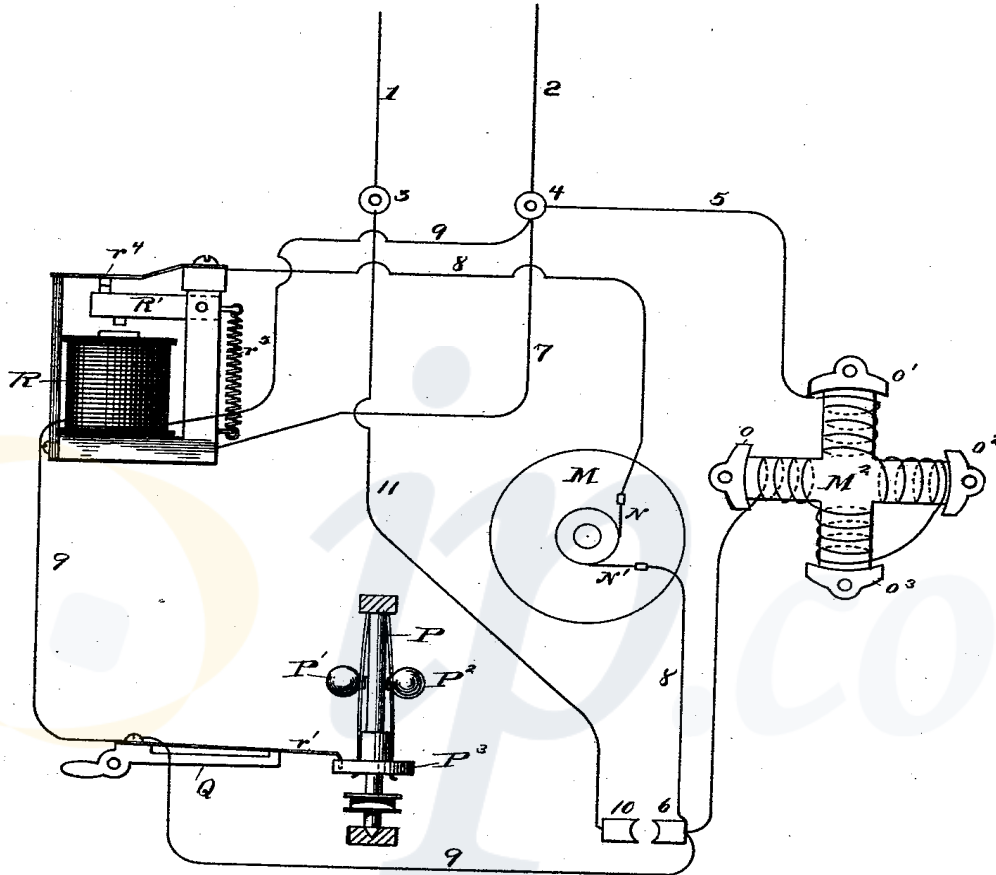

Witnesses
E. Rowland
William H. ...

Inventor
Thomas A. Edison
By his Attorneys
Dye & Seely

UNITED STATES PATENT OFFICE.

THOMAS A. EDISON, OF LLEWELLYN PARK, NEW JERSEY, ASSIGNOR TO THE EDISON PHONOGRAPH COMPANY, OF NEW JERSEY.

PHONOGRAPH.

SPECIFICATION forming part of Letters Patent No. 499,879, dated June 20, 1893.

Application filed July 30, 1888. Serial No. 281,453. (No model.)

To all whom it may concern:

Be it known that I, THOMAS A. EDISON, a citizen of the United States, residing at Llewellyn Park, in the county of Essex and State of New Jersey, have invented a certain new and useful Improvement in Phonographs, (Case No. 792,) of which the following is a specification.

My invention relates to improvements in the mechanism of my phonograph, whereby it is made more convenient and efficient in operation.

The invention consists in the various novel devices and combinations of parts and in the method as fully hereinafter explained and pointed out by the claims.

In the accompanying drawings forming a part hereof,—Figure 1, is a front elevation of the complete machine with the front of the case broken away to show the driving motor. Fig. 2, is a top view of the complete machine. Fig. 3, is a top view of the phonograph proper on a somewhat larger scale omitting the driving and governing devices. Fig. 4, is a sectional view illustrating the movable center for supporting the outer end of the phonogram cylinder carrying shaft. Fig. 5, is an end view of the phonograph. Fig. 6, is a sectional view showing the traveler arm and connected parts. Fig. 7, is a top view of the driving motor. Fig. 8, is a sectional view of such motor. Fig. 9, is an end elevation of the speed governor. Fig. 10, is an elevation and partial section of the governor taken at right angles to Fig. 9. Fig. 11, is a top view of the contact arm of the governor; and Fig. 12, is a view principally in diagram showing the circuit connections of the electric motor and governor.

A is the frame of the phonograph proper which is mounted upon a box B, which in turn is mounted upon a suitable base C. The frame A is supported upon one end of the box B so that it overhangs such box to make room for a receptacle A³, which stands upon the base C under the overhanging phonograph frame and receives the shavings which are cut from the phonogram cylinder.

Between the phonograph frame A and the box B are placed cushions *a* of elastic material such as soft rubber, which, to a desirable

extent, prevent the vibrations of the motor contained within the box B from being transferred to the phonograph frame to the injury of the recording or reproduction of the sounds. 55

The frame A is secured to the box B by means of screws *b* which pass through slotted lugs *b'* on the frame A into the top of the box B. Lugs *b*² on the base B rise up on each side of the bottom edge of the frame A so as to hold such frame against lateral displacement. A screw *c* passing through a part of the frame A sets against a lug *c'* on the base B (shown in dotted lines in Fig. 1). 60

The screw *c* serves to adjust the frame A on the box B for the purpose of tightening the driving belt as will be presently explained, and the lugs *b'* are slotted to permit of this movement, the screws *b* being finally tightened after the proper adjustment of the driving belt has been secured. 65 70

D is the shaft of the phonograph, which is arranged horizontally and longitudinally upon the frame A. This shaft is held upon stationary centers so as to turn true and for the purpose of compensating for any wear. At the inner end of the frame A a standard *d* rises, through which passes the adjustable and removable centering pin *d'*, which is held by a set screw *d*² passing through the top of the standard *d*. At the outer end of the phonograph shaft D the centering pin *e* is carried by a swinging arm D'. This swinging arm D' is pivoted upon a side extension A' of the frame A at one end and at its other end it is removably attached to a side extension A² of the frame A by means of a bolt *e'* and a thumb nut *e*². This bolt *e'* is pivoted on the end of the side extension A² of the frame A so as to swing vertically and it enters a slot *e*³ in the end of the swinging arm D'. By loosening the nut *e*², the bolt *e'* can be swung downwardly out of the slot *e*³ when the arm D' is free to be swung upon its pivot thus exposing the outer end of the phonograph shaft D, while by swinging the arm D' inwardly, the center *e* will properly engage with the end of the shaft D and by lifting the bolt *e'* and tightening the thumb nut *e*² the arm D' will be fastened rigidly against the end of the side extension A² of the frame A. To prevent the shaft D from too great a displacement when the arm D' is 75 80 85 90 95 100

swung outwardly, it passes through a slotted standard d^3 , which rises from the base A and encircles the shaft D loosely.

The shaft D is prevented from longitudinal displacement by means of the pulley E which is secured to the inner end of the shaft D and extends below the top of the frame A, so that when the arm D' is swung outwardly the pulley E will prevent the inner end of the shaft from disengaging totally from the center d' by reason of its impingement against the base A.

The center e is a pin which passes through the arm D' and is made adjustable by means of a screw f which turns into the arm D' and has a flange f' on its head which engages with a slot in the side of the pin e . By turning the screw f it will be seen that the center pin e will be adjusted and this without turning the center pin; the turning of the center pin might be attended with a disturbance of the relative adjustment of the parts.

Upon the shaft D between the standard d^3 and the swinging arm D' is mounted the phonogram cylinder F. This is preferably a cylinder having a slight taper on its external surface, its smaller end being at the outer end of the shaft. The standard d^3 is at the end of the top plate of the frame A, the extension of such frame beyond the box B being effected by the side bars A' A². The phonogram cylinder F being located between the side bars A' A² overhangs the frame, leaving a clear space beneath the cylinder through which the cuttings from the blank drop into the receptacle A³. The tapering cylinder F is adapted to receive a cylindrical phonogram blank F' having a tapering bore adapted to fit the surface of the cylinder. By swinging the arm D' outwardly, the phonogram blank F' can be removed from the cylinder or placed upon it. To stiffen the side bars A' A² of the frame and to prevent a vibrating or tuning fork action, which would injure the record, such side bars are connected by a cross bar A⁴ at their outer ends, such cross bar A⁴ curving downwardly out of the way so as not to interfere with the manipulations of the blanks.

G is a stationary rod which is mounted in standards on the frame A and its side bar A' in rear of and parallel with the shaft D. Upon the rod G is a sleeve G', which is adapted to slide and turn freely upon such rod, and which is of less length than the rod, so that its longitudinal movement thereon will be equal at least to the length of the phonogram cylinder F. Secured to the outer end of the sleeve G' is the rocking holding arm H which is rigidly fixed to said sleeve and projects upwardly and forward over the top of the phonogram cylinder. On its upper end the rocking holding arm H carries the swinging spectacle frame H', which is pivoted to said rocking holding arm so as to swing laterally across it. A spring pin g having a beveled end enters bevel slots g' in the hub of the spectacle

frame so as to hold the spectacle frame by spring pressure at either limit of its swinging movement. The eyes of the spectacle frame carry the recorder H² and the reproducer H³, which are brought alternately into operative relation with the surface of the phonogram blank by the swinging of the spectacle frame.

The head of the rocking holding arm H is provided with laterally extending arms g^2 g^3 through which pass set screws g^4 g^5 . These set screws bear against the spectacle frame when it is swung in one direction or the other, so as to adjust the spectacle frame to bring the recorder or reproducer into the desired relation with the surface of the blank. The screw g^4 effects this adjustment for the reproducer, the result being to adjust the reproducing point laterally across the track of record, so as to bring it into the best relation with the record for reproducing the sounds, which relation can be determined by listening to the instrument. The screw g^5 serves to adjust the relation of the recorder with the surface of the blank. The purpose of this is to enable the production of a double record upon the same blank and in parallel spiral lines.

It is evident that if the recording point be made narrow relative to the feeding movement, the space between the spiral lines of record may be as wide or wider than the track of the record itself. If such is the case the unoccupied space between the lines of record may be utilized for producing a second record. The screw g^5 enables the operator to adjust the recording point so as to track in this space between the lines of the first record, and the screw g^4 enables the operator to adjust the reproducer so that it will track on either record. The eyes of the spectacle frame are provided with fingers h through which pass the adjusting screws h' which rest upon the guide rest I, which is secured to the side bar A² of the frame in front of the phonogram cylinder and parallel with its axis. The bearing of the adjusting screw h' upon the straight guide rest I causes the recorder or reproducer to advance in a straight line along the surface of the blank. The ends of the adjusting screws h' which bear upon the guide rest I are enlarged so as to overlap said guide rest for a purpose which will be presently explained.

Upon the inner end of the sleeve G' is mounted the traveler arm I', which is adapted to turn freely on the sleeve G'. This traveler arm projects forward over the shaft D between the standard d^3 and the pulley E and has a section of a nut h^2 attached removably to its lower edge and engaging with a fine screw thread h^3 , which is cut upon the shaft D between the standard d^3 and the pulley E. The nut section h^2 is removably secured to the traveler arm I' by means of screws as shown, so that it can be readily replaced when worn out; it is also made remov-

able so that it can be made of steel and have a finely cut screw surface. The traveler arm itself may be of cast iron. The traveler arm projects over the shaft D and in front of it, and at its forward end is provided with a downwardly projecting finger i having its lower end i' turned upwardly to form a hook, the end of which hook terminates in a knife edge which engages the under side of a screw shaft i^2 mounted in standards on the top plate of the frame A in front of and parallel with the screw cut section of the shaft D. The shaft i^2 is provided with a screw thread i^2 which is coarser than the screw thread h^3 . The function of the screw thread i^2 is to move the traveler arm back with a speed which is greater than the forward movement which is given such traveler arm by the screw thread h^3 . This screw thread i^2 is a ratchet thread so as to engage effectively with the hook end of the finger i and to move the traveler arm backwardly without causing a friction which would result from a tendency to force the point i' out of the thread were such screw thread beveled equally in opposite directions. The shaft I^2 is driven from the shaft D by means of a belt i^3 which passes over small pulleys on both shafts. A lug j on the sleeve G' engages with a lug j' on the hub of the traveler arm I' , when the sleeve G' is turned back to the limit of its turning movement. This limit is determined by a finger j^2 on the rocking holding arm, which strikes the edge of the base A or the side bar A' when the spectacle frame is thrown backwardly over the center so that it will maintain itself in the elevated position. The lug j does not strike the lug j' until the limit of movement is nearly reached so that the effect will be to just lift the traveler nut h^2 out of engagement with the screw thread h^3 without engaging the point i' of the finger i with the reversing thread i^2 . Before this limit of the lifting movement of the spectacle frame is reached such movement does not affect the traveler arm. In front of the guide rest I and the reversing shaft I^2 and extending the entire length of the frame A and the side bar A^2 is a turning guide bar J. This turning guide bar is pivoted in lugs j^2 projecting from the frame, it being held eccentrically by centers j^3 passing through the lugs j^2 and engaging with the outer edge of the bar J at its ends. The inner edge j^4 of the bar J is made as a straight edge, and the enlarged ends of the adjusting screws h' project over this straight edge j^4 , and likewise a projection j^5 on the finger i attached to the end of the traveler arm I' projects over this edge j^4 . To one end of the bar J are secured two fingers k k' between which plays a cam k^2 , secured to the end of a turning stud k^3 having a thumb piece on its end. A spring k^4 throws the finger k down against the cam k^2 throwing the straight edge j^4 downward. The function of the cam k^2 is to turn the bar J against the tension of the spring k^4 and to

lift the edge j^4 against the tension of the spring. For this purpose the cam k^2 is provided with two risers k^5 , k^6 , the rise k^5 being less than the rise k^6 . Now by turning the cam k^2 with the fingers the effect will be to turn the bar J and to lift the edge j^4 by two successive movements. The effect of the first movement, that produced by the rise k^5 of the cam, is to lift the spectacle frame so that the recorder or reproducer will be disengaged from the surface of the blank and to lift the traveler nut h^2 out of the feeding screw h^3 so that the further feeding of the spectacle frame will be stopped. The clearance between the edge j^4 and the shoulder j^5 is slightly greater than that between the edge j^4 and the adjusting screw h' so that the recorder or reproducer will be first disengaged from the surface of the blank before the traveler nut is disengaged from its feed screw in order to prevent injury to the blank or the record on it. The effect of the second step of the movement, that produced by the rise k^6 of the cam, is to simultaneously raise the spectacle frame and traveler arm to a farther extent and to throw the point i' of the finger i into engagement with the reversing screw thread i^2 . This reverses the movement of the spectacle frame so that in reproducing the matter can be repeated to any extent desired. An arm m may be attached to the turning bar J and be connected by a cord or wire with a treadle J' so that the movements of the bar J may be produced by the foot of the operator. A scale K is attached to the front of the bar J and pointers m' are secured to the fingers h and project down in front of this scale so that the position of the recorder or the reproducer with relation to the surface of the phonogram blank can be determined. An adjustable knife L is pivoted to the rocking holding arm H for the purpose of turning off the surface of the blank. The swinging arm D' is provided with a projecting flange m^2 projecting inwardly around the center pin e and entering the end of the phonogram cylinder F, so as to act as a guard to the center pin, preventing the material which is cut from the blank from entering the space around the center and gumming up the bearing. A guard plate m^3 is attached to the side bar A' in rear of the phonogram cylinder so as to guide the shavings cut from the blank into the receptacle A^3 . Such shavings by reason of the movement given them by the turning of the cylinder, tend to pass over the extension A' of the frame; they are intercepted by the guard plate m^3 .

For driving the phonograph I prefer to employ an electric motor. This is inclosed in the box B, the armature M of the motor being mounted on a vertical shaft M' , which passes through the top plate of the box B above which it is provided with a pulley n . An endless belt n' passes around this pulley n and passes under two guide pulleys n^2 , n^3 , which are held by centers in the frame A near the lower edge of the pulley E. The horizon-

tal shaft D of the phonograph is thus driven from the vertical shaft M' of the motor through an endless belt, whose direction is changed from a horizontal to a vertical plane by means of the guide pulleys n^2, n^3 . This belt connection between the motor and phonograph shaft is preferable to gearing since the slight mechanical vibrations of the motor are not transferred thereby to the phonograph. It will be seen that by adjusting the set screw any tension desired can be given to the belt n' . The form of electric motor employed is a multipolar motor, it having four field magnet poles o, o', o^2, o^3 . These poles project upwardly from a four armed plate M². The armature M revolves above the plate M², the arms of the plate M² being wound with the field magnet wire. The plate M² is supported from the bottom of the box B by suitable legs o^4 and is steadied from the top plate of the box B by studs o^5 . The vertical shaft M' of the motor is stepped in the center of the plate M². A hole is cut through the center of the plate M² and into this hole is introduced from the under side of the plate M² a block p of metal carrying in its upper end a flat agate p' . The plug step p is made adjustable by means of a screw p^2 entering the bottom of the plate M² and bearing at one side of its head on the plug p , so that by turning this screw the plug p can be adjusted. The lower end of the shaft M' is brought to a rounded point where it rests on the agate p' , the shaft above the agate being surrounded by a bushing p^3 of brass or other suitable material; the shaft at its upper end is held by a center pin p^4 . The commutator brushes of the motor are shown at N N'. An oil tube N² extends from the top plate of the box B down to the step bearing of the motor shaft. The armature of the motor is a Gramme ring which is secured to a hub on the shaft by means of three layers O, O', O² of wood, which are placed so that the grain of the middle layer is at right angles to the grain of the two outside layers. The ring armature is of considerable size, so as to act as a fly wheel and so as to have a considerable surface velocity with a relatively low axle speed. The motor employed, being an electro-dynamic motor, has a high degree of efficiency, which efficiency is increased by the fact that it is a multipolar motor, since the magnetism has a shorter distance to travel through the iron of the armature and a more intense field is produced. With the fly wheel form of armature it would not be possible to get as intense a field or one as uniform with a field magnet having but two poles. I have also found that by using a motor with a vertical shaft a great reduction can be made in the power of the driving battery over what would be required by a motor mounted on a horizontal shaft. The motor being nicely balanced on its jewel step seems to require very little power to drive it and does not produce troublesome vibrations in the phonograph.

To control the speed of the motor and make it uniform, I provide a governor. This governor has a shaft P which is driven by an endless belt q from a pulley on the motor shaft. Centrifugal balls P' P² are secured to springs q', q^2 which are attached at their upper ends to the shaft P and at their lower ends hold a plate P³ which surrounds the shaft P and is raised and lowered by the centrifugal balls P' P². The shaft P is a vertical shaft stepped at its lower end on the flat agate q^3 and held at its upper end by a center pin q^4 . The movement of the plate P³ by the governor balls serves to make and break circuit between two springs r, r' which are held by a pivoted lever Q which is adjustable by means of a screw Q' passing through a suitable support with which its screw thread engages and also passing through the end of the lever Q below which it is provided with a nut and above which it has a spring r^2 to prevent any lost motion at the connection between the screw Q' and the lever Q. It will be seen that by adjusting the elevation of the lever Q the point at which the plate P³ will touch both the springs r, r' will be varied, and since this point is the point at which the speed of the motor is checked, it will be seen that the motor can be varied in its speed, which it is desirable to do in reproducing the sounds from phonogram blanks, since the speed at which the sound record was made will be indicated upon the blank and the machine can be set for that speed. The head Q² of the screw Q' is provided with a suitable index as shown, by means of which and the pointer r^3 the adjustment of the governor can be determined. R is an electro-magnet whose armature R' breaks circuit at its back point r^4 , the armature being retracted by a spring r^5 . The electric connections of the motor and the governor are illustrated in Fig. 12, in which 1, 2, represent the wires from the battery or other source of electrical energy leading to the binding posts 3, 4, which are located upon the box B. From the binding post 4, a wire 5 passes to the field magnet of the motor and from thence to the plate 6 of a plug switch. From the binding post 4 also extends a wire 7 connected to the base of the magnet R and hence to its armature R'. From the insulated back point r^4 of the magnet a wire 8 extends to the armature M of the motor and from thence to the plate 6 of the plug switch; also extending from the binding post 4 is a wire 9 which includes the coils of the magnet R and thence extends to the spring r at which the wire is broken. The wire 9 is continued however from the spring r' to the plate 6 of the plug switch. From the plate 10 of the plug switch a return wire 11 is run back to the binding post 3. It will be seen that the armature of the motor, its field magnet and the governor magnet R are in three separate multiple arc circuits from the battery. The circuit of the field magnet is never opened except at the plug switch, which

opens all of the circuits at once. The circuit of the armature however of the motor is opened whenever the magnet R moves its armature R' off of the back point r^4 . The magnet R is wound to a high resistance and is extremely sensitive in its action, so that the instant the circuit to this magnet is closed by the plate P³ touching the springs $r r'$, the magnet will act and will open the circuit of the armature. This makes a much more sensitive governing device than if it were attempted to control the circuit of the armature by means of the governor directly. The field magnet circuit of the motor not being opened by the governor the spark which would be caused by the discharge of the field magnets will not be present.

What I claim as my invention is—

1. In a phonograph, the combination with the phonogram cylinder and its carrying shaft, of centers upon which said shaft turns and a swinging arm upon which one of said centers is mounted, substantially as set forth.

2. In a phonograph, the combination with the phonogram cylinder and its carrying shaft, of centers on which the said shaft turns, a swinging arm carrying one of said centers and a standard through which such shaft passes loosely for preventing displacement of the shaft when the center is swung away from its end, substantially as set forth.

3. In a phonograph, the combination with the phonogram cylinder and its carrying shaft, of centers on which said shaft turns, a swinging arm carrying one of said centers and the driving pulley on the shaft extending below the top of the frame so as to lock the shaft against longitudinal displacement, substantially as set forth.

4. In a phonograph, the combination with the cylinder shaft, of the cylinder mounted on one end of said shaft, centers on which the shaft turns and a swinging arm carrying the center at the cylinder end of the shaft whereby the end of the cylinder can be exposed for receiving or removing the phonogram blank, substantially as set forth.

5. In a phonograph, the combination with the supporting frame, of a shaft overhanging the frame, the phonogram cylinder placed on the overhanging portion of the shaft and a removable bearing for this overhanging end of the shaft, substantially as set forth.

6. In a phonograph, the combination with the supporting frame, of the cylinder shaft mounted upon such frame and overhanging the same at one end, the phonogram cylinder mounted on the overhanging end of the shaft, side bars extending from the frame out to the end of the shaft and a movable arm connecting such side bars and carrying the outer bearing of the shaft, substantially as set forth.

7. In a phonograph, the combination with the frame A, having side bars A' A² and the phonogram cylinder and shaft, of the swinging arm D' carrying the center for the outer end of the shaft and pivoted upon one of said

side bars and locked to the other side bar by the swinging bolt e' and nut e^2 , substantially as set forth.

8. In a phonograph, the combination with the frame A having side bars A' A² and the phonogram cylinder and shaft, of the swinging arm D' carrying the center for the outer end of the shaft and the bar A⁴ connecting the side bars of the frame, substantially as set forth.

9. In a phonograph, the combination with the rocking holding arm and the traveler arm, of a movable bar acting upon both of such arms and lifting them together, substantially as set forth.

10. In a phonograph, the combination with the rocking holding arm and the traveler arm, of a bar having a straight edge extending beneath both of such arms and pivoted so as to be capable of a turning movement, whereby it will lift said arms together, substantially as set forth.

11. In a phonograph, the combination with the rocking holding arm and the traveler arm, of the pivoted lifting bar extending under both the rocking holding arm and the traveler arm and a cam for turning said lifting bar, substantially as set forth.

12. In a phonograph, the combination with the rocking holding arm and the traveler arm, of the feeding and reversing screws, the turning lifting bar and the cam having two rises for giving such lifting bar two successive movements, substantially as set forth.

13. In a phonograph, the combination with the rocking holding arm and the traveler arm, of the stud for lifting the traveler arm when the rocking holding arm has reached the limit of its lifting movement, substantially as set forth.

14. In a phonograph, the combination with the supporting rod and the sleeve sliding and turning thereon, of the rocking holding arm secured to said sleeve, the traveler arm turning upon such sleeve, a stop for determining the limit of the lifting movement of the rocking holding arm and studs for lifting the traveler arm when the rocking holding arm has reached the limit of its lifting movement, substantially as set forth.

15. In a phonograph, the combination with the rocking holding arm and the traveler arm, of the turning lifting bar acting upon both of said arms and the foot treadle connected with said turning lifting bar for operating it, substantially as set forth.

16. The method of producing more than one record on the same phonogram blank consisting of first making one record thereon and then adjusting the recording point to an intermediate position between the adjacent spiral lines of the preceding record and making an additional record, whereby without increasing the fineness of the feeding screw more matter can be recorded upon a phonogram blank of given length, substantially as set forth.

70

75

80

85

90

95

100

105

110

115

120

125

130

- 17. In a phonograph, the combination with the rocking holding arm, of the guide rest and the adjustment upon such guide rest having a bearing overlapping the guide rest and a turning lifting bar beneath the overlapping bearing, substantially as set forth. 5
- 18. In a phonograph, the combination with the phonogram cylinder and shaft, of the swinging arm carrying the center for the cylinder end of the shaft and the wax guard surrounding such center and entering the end of the cylinder, substantially as set forth. 10
- 19. In a phonograph, the combination with the phonogram cylinder and the turning off knife or tool, of the wax guard in rear of such cylinder for directing the shavings into a receptacle beneath the cylinder, substantially as set forth. 15
- 20. In a phonograph, the combination with the horizontal main shaft, the phonogram blank carrier revolved thereby, and the recording and reproducing devices, of an electric motor mounted upon a vertical shaft, and a belt connection between the motor shaft and the phonograph shaft, substantially as set forth. 20
- 21. In a phonograph, the combination with the phonograph shaft, the phonogram blank carrier revolved thereby, and the recording and reproducing devices, of an electric motor connected with said shaft for driving the same, the armature and the field magnet of said motor being connected in multiple arc, and a speed governor controlling the armature circuit, substantially as set forth. 25
- 22. In a phonograph, the combination with the phonograph shaft, the phonogram blank carrier revolved thereby, and the recording and reproducing devices, of an electric motor connected with said shaft for driving the same, and having its armature and its field magnet in separate multiple arc circuits, a magnet controlling the armature circuit, and a centrifugal governor controlling the said magnet, substantially as set forth. 30
- 23. In a phonograph, the combination with the phonograph shaft, the phonogram blank carrier revolved thereby, and the recording and reproducing devices, of an electric motor connected with said shaft for driving the same, a speed governor controlling the speed of said motor by opening the circuit thereof when a predetermined speed has been obtained, and an adjusting screw for varying the point at which the governor will affect the circuit, substantially as set forth. 35
- 24. In a phonograph, the combination with the phonograph shaft, the phonogram blank

- carrier revolved thereby, and the recording and reproducing devices, of an electric motor connected with said shaft for driving the same, a centrifugal governor controlling such motor by closing circuit at contacts and an adjustment for varying the position of such contacts whereby the speed of the motor can be varied, substantially as set forth. 60
 - 25. In a phonograph, the combination with the phonograph shaft, the phonogram blank carrier revolved thereby, and the recording and reproducing devices, of an electric motor connected with said shaft for driving the same, a magnet controlling said motor, contacts mounted upon an adjustably pivoted lever at which the magnet circuit is broken and a centrifugal governor moving a disk which closes the magnet circuit at such contacts, substantially as set forth. 65
 - 26. In a phonograph, the combination with the frame supporting the phonograph shaft, the phonogram blank carrier, and the recording and reproducing devices, of an electric motor mounted upon a base and connected by a belt with the phonograph shaft, and means for adjusting the phonograph frame to tighten said belt, substantially as set forth. 70
 - 27. In a phonograph, the combination with the phonograph proper in which are combined a phonograph shaft, a phonogram blank carrier revolved thereby, and recording and reproducing devices, the same being mounted upon a separate frame, of a base carrying a motor connected with the said shaft for driving the same, and cushions of elastic material between said base and the phonograph frame, substantially as set forth. 75
 - 28. In a phonograph, the combination with the frame of the phonograph proper, of the base carrying a motor connected by a belt with the phonograph shaft, guiding lugs upon the base, slotted lugs and screws for securing the phonograph frame to the base and an adjusting screw for adjusting the phonograph frame upon the base for the purpose of tightening the belt, substantially as set forth. 80
 - 29. In a phonograph, the combination with the feed screw and the traveler arm, of the nut section secured rigidly but removably to said traveler arm and engaging with said feed screw, substantially as set forth. 85
- This specification signed and witnessed this 27th day of July, 1888. 90

THOS. A. EDISON.

Witnesses:
 RICHD. N. DYER,
 WILLIAM PELZER.